

Customer Information Sheet

IF IN DOUBT - ASK

©

NOT TO SCALE

THIRD ANGLE PROJECTION

ALL DIMENSIONS IN mm

ORDER CODE:
F20-100XXX45R
No. OF CONTACTS: _____
060, 080

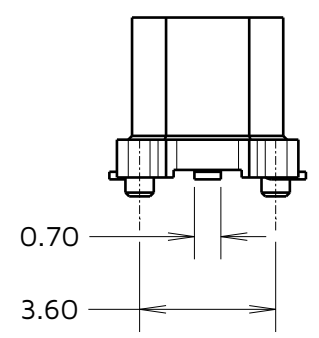
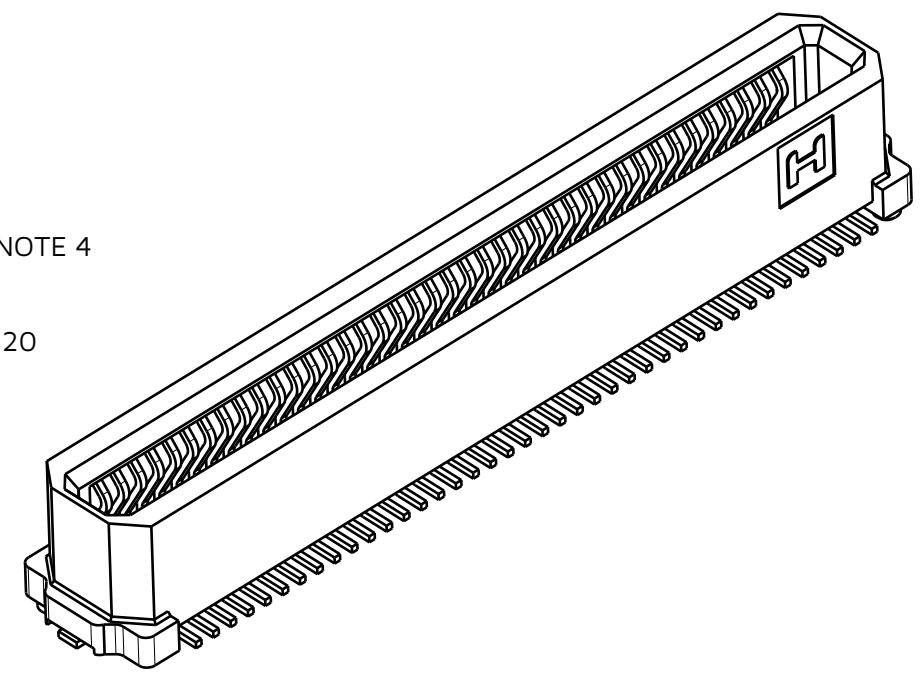
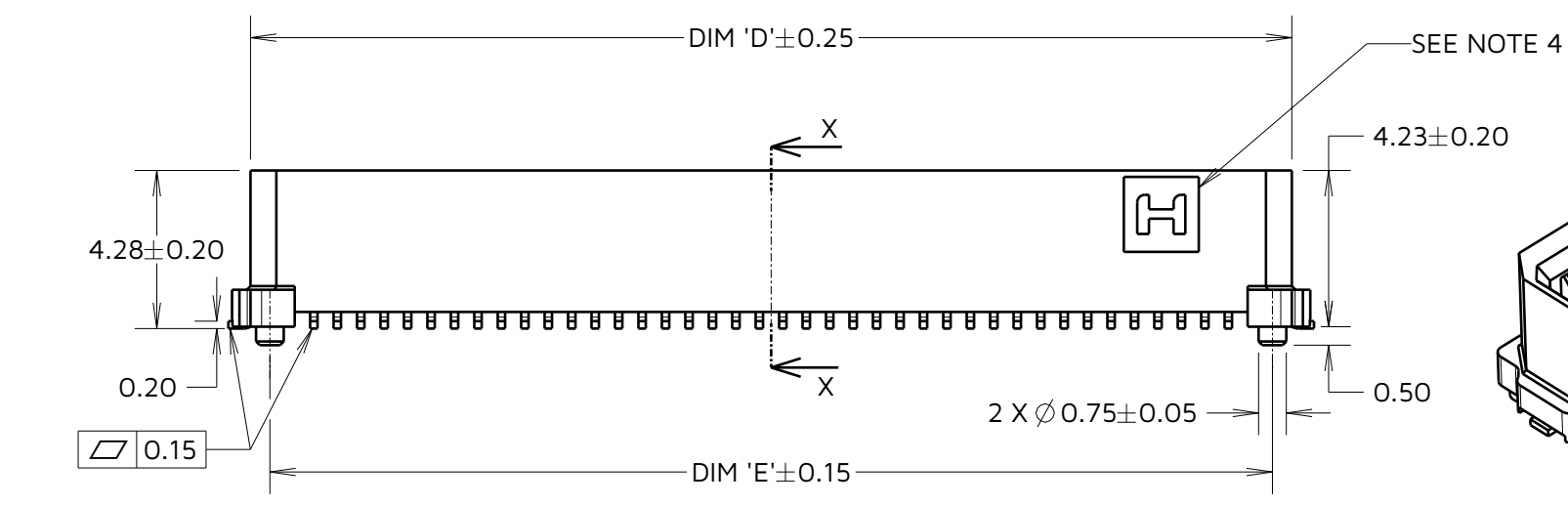
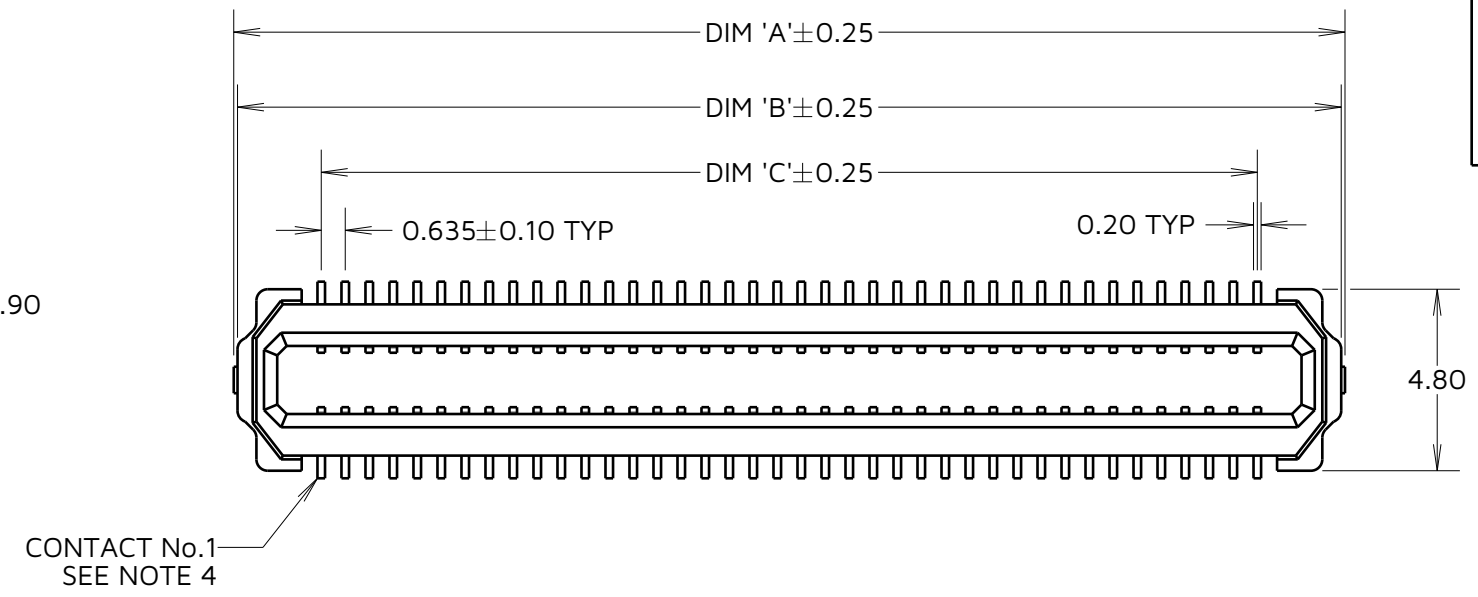
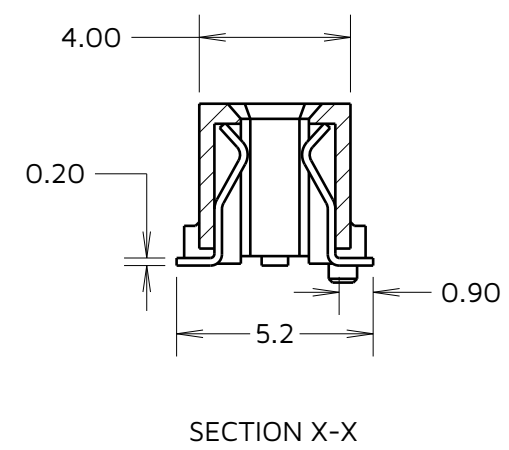
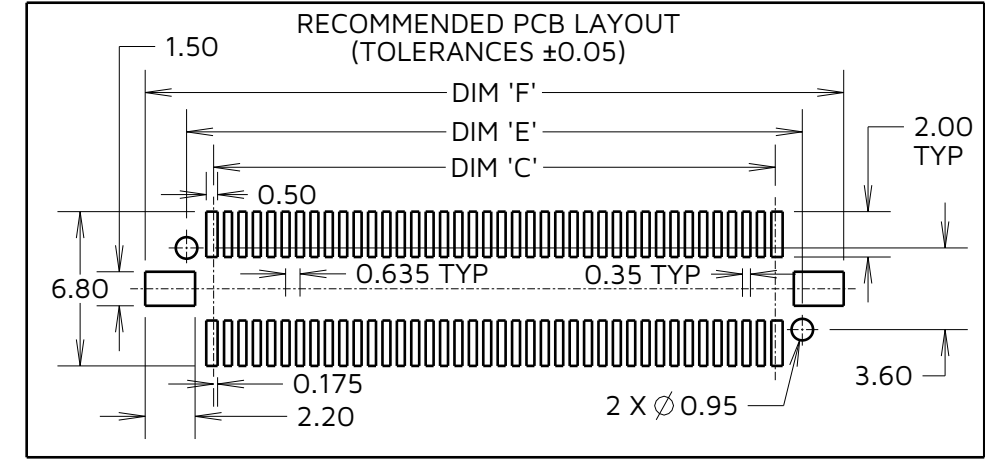

TABLE 1: DIMENSIONS

No. OF CONTACTS	DIM 'A'	DIM 'B'	DIM 'C'	DIM 'D'	DIM 'E'	DIM 'F'
60	23.05	22.85	18.42	21.85	20.80	24.45
80	29.40	29.20	24.77	28.20	27.15	30.80

TOLERANCES	
X = ±0.30mm	X.° = ±5.0°
.X = ±0.25mm	.X.° = ±3.0°
.XX = ±0.15mm	.XX.° = ±2.0°
.XXX = ±0.10mm	.XXX.° = ±1.0°

AB	2	24.02.24	33735
NAME	ISS.	DATE	CN/CO
APPROVED: A.YEOMANS			
CHECKED: M.PLESTED			
DRAWN: A.BOXALL			
ASSEMBLY DRG:			

- NOTES:
- SEE COMPONENT SPECIFICATION C057XX (LATEST ISSUE) FOR COMPLETE CONNECTOR SPECIFICATIONS.
 - PART SHOWN "F20-10008045R", SEE ORDER CODE FOR POSSIBLE CONFIGURATIONS.
 - SEE SHEET 4 FOR TAPE & REEL DETAILS.
 - HARWIN LOGO SHOWN IN THIS ORIENTATION FOR REFERENCE ONLY. LOGO IS UNRELATED TO CONTACT No.1, AS CONTACT No.1 WILL ALWAYS BE THIS POSITION.

HARWIN

www.harwin.com

TOLERANCES
X = ±1mm
X.X = ±0.50mm
X.XX = ±0.20mm
X.XXX = ±0.01mm
ANGLES = ±5°
UNLESS STATED

THIS DRAWING AND ANY INFORMATION OR DESCRIPTIVE MATTER SET OUT HEREON ARE CONFIDENTIAL AND COPYRIGHT PROPERTY OF THE HARWIN GROUP AND MUST NOT BE DISCLOSED, LOANED, COPIED OR USED FOR MANUFACTURING, TENDERING OR FOR ANY OTHER PURPOSE WITHOUT THEIR WRITTEN PERMISSION.

MATERIAL:

SEE NOTE 1

TITLE: **0.635mm PITCH FEMALE FLECTO CONNECTOR (4.28mm HEIGHT)**

DRAWING NUMBER:
F20-100XXX45R

Customer Information Sheet

IF IN DOUBT - ASK

©

NOT TO SCALE

THIRD ANGLE PROJECTION

ALL DIMENSIONS IN mm

ORDER CODE:
F20-100XXX45R

No. OF CONTACTS:
060, 080

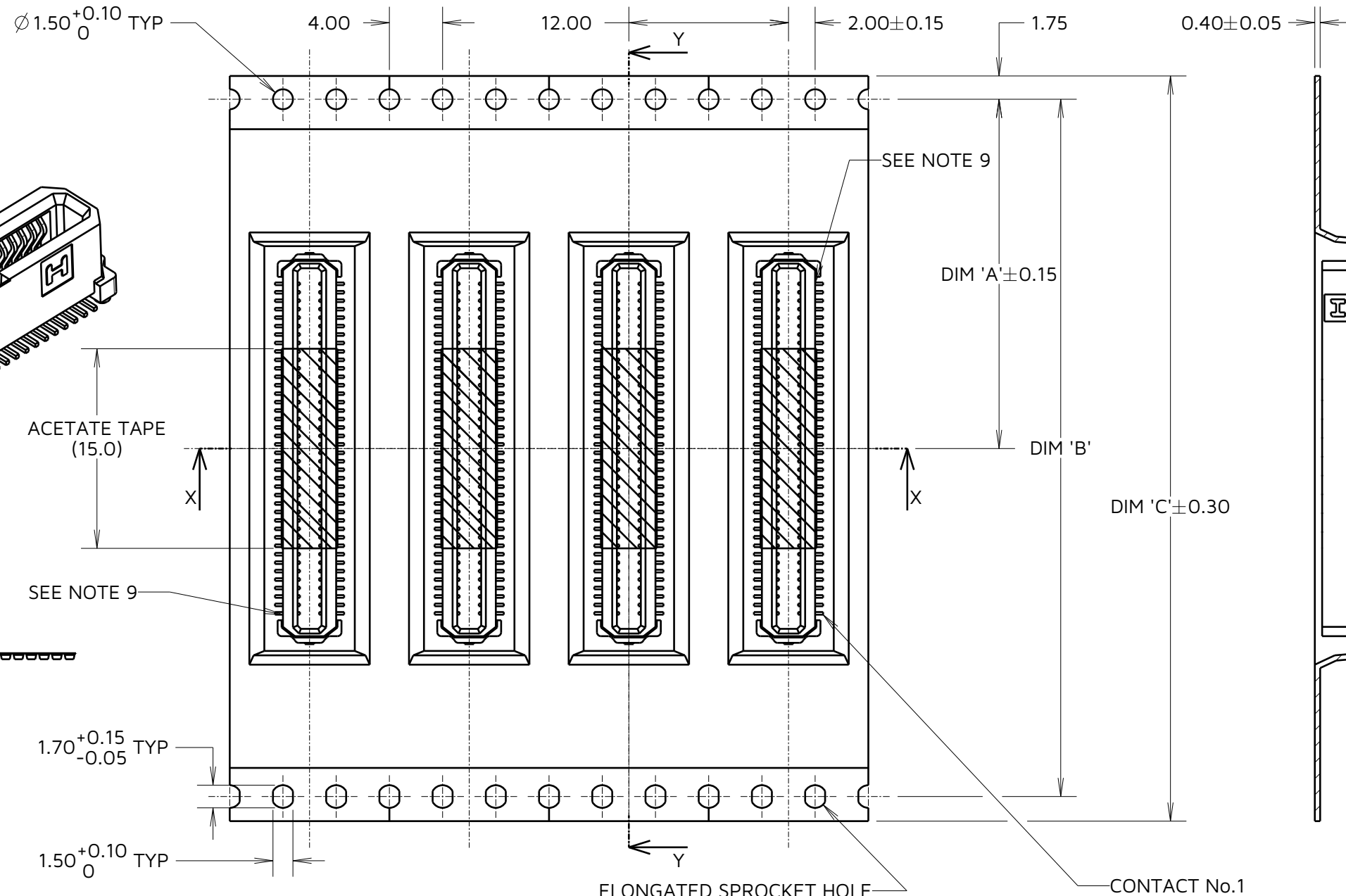

SECTION Y-Y

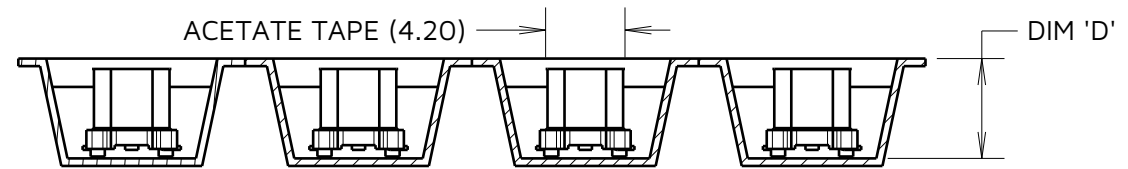
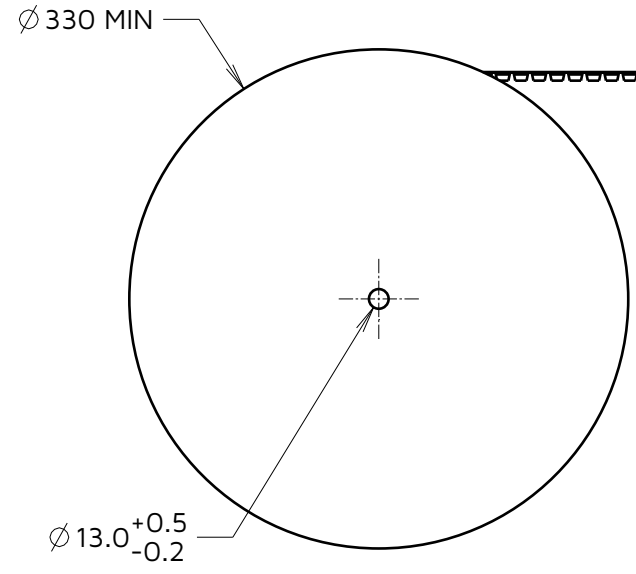

REEL DIRECTION

SECTION X-X

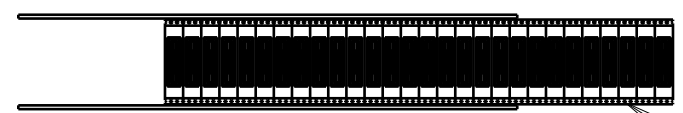

ELONGATED SPROCKET HOLE

No. OF CONTACTS	DIM 'A'	DIM 'B'	DIM 'C'	DIM 'D'
60	20.20	40.40	44.00	05.30
80	26.20	52.40	56.00	05.28

AB	2	24.02.24	33735
NAME	ISS.	DATE	CN/CO
APPROVED:		A.YEOMANS	
CHECKED:		M.PLESTED	
DRAWN:		A.BOXALL	
ASSEMBLY DRG:			

- NOTES:
- PRODUCT TAPE AND REELED IN ACCORDANCE WITH EIA-481 STANDARD.
 - CARRIER TAPE MATERIAL: BLACK POLYSTYRENE.
 - COMPONENTS PER REEL: 1000 PCS
 - TAPE POCKETS MAY DIFFER VISUALLY FROM DRAWING.
 - POSITION OF HARWIN LOGO IS NOT CRITICAL AND MAY BE IN EITHER MARKED POSITION. LOGO DOES NOT AFFECT CONTACT No.1.

HARWIN

www.harwin.com

TOLERANCES
 X. = ± 1 mm
 X.X = ± 0.50 mm
 X.XX = ± 0.20 mm
 X.XXX = ± 0.01 mm
 ANGLES = $\pm 5^\circ$
 UNLESS STATED

THIS DRAWING AND ANY INFORMATION OR DESCRIPTIVE MATTER SET OUT HEREON ARE CONFIDENTIAL AND COPYRIGHT PROPERTY OF THE HARWIN GROUP AND MUST NOT BE DISCLOSED, LOANED, COPIED OR USED FOR MANUFACTURING, TENDERING OR FOR ANY OTHER PURPOSE WITHOUT THEIR WRITTEN PERMISSION.

MATERIAL:
SEE NOTE 6

TITLE: **0.635mm PITCH FEMALE FLECTO CONNECTOR (4.28mm HEIGHT)**

DRAWING NUMBER:
F20-100XXX45R