

Customer Information Sheet

DRAWING No.: M80-023

IF IN DOUBT - ASK

©

NOT TO SCALE

THIRD ANGLE PROJECTION

ALL DIMENSIONS IN mm

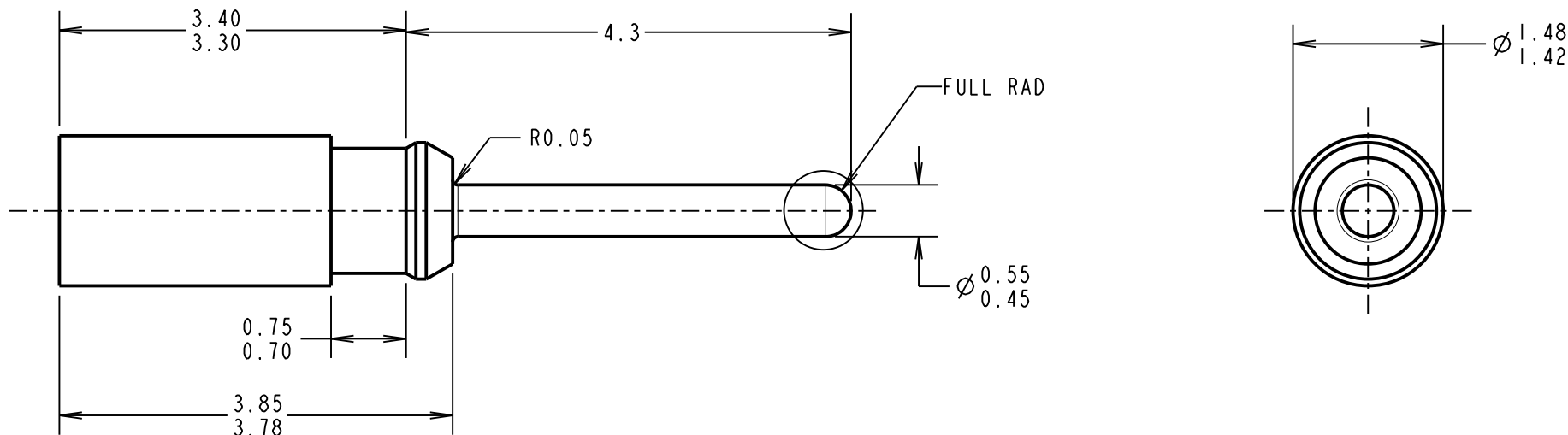

NOTES:

1. SUITABLE FOR USE IN ANY M80 FEMALE PC TAIL MOULDING AS A REPLACEMENT FOR A STANDARD CONTACT, TO GIVE ADDITIONAL POLARISATION.
2. THIS BLANKING PIN CAN ALSO BE USED WITH CABLE HOUSINGS - BUT MUST BE INSERTED FROM THE FRONT FACE OF THE CONNECTOR, RATHER THAN THE REAR.
3. MATING MALE CONNECTOR, MUST HAVE THE EQUIVALENT PIN REMOVED FOR CONNECTORS TO MATE CORRECTLY.

MGP	8	02.11.21	31105
NAME	ISS.	DATE	CN/CO
APPROVED: MGP			
CHECKED: MR			
DRAWN: P. D. COLLINS			
CUSTOMER REF.:			
ASSEMBLY DRG:			

HARWIN

www.harwin.com
technical@harwin.com

THIS DRAWING AND ANY INFORMATION OR DESCRIPTIVE MATTER SET OUT HEREON ARE CONFIDENTIAL AND COPYRIGHT PROPERTY OF THE HARWIN GROUP AND MUST NOT BE DISCLOSED, LOANED, COPIED OR USED FOR MANUFACTURING, TENDERING OR FOR ANY OTHER PURPOSE WITHOUT THEIR WRITTEN PERMISSION.

TOLERANCES
 X. = ±1mm
 X.X = ±0.50mm
 X.XX = ±0.20mm
 X.XXX = ±0.01mm
 ANGLES = ±5°
 UNLESS STATED

MATERIAL:

BRASS

FINISH:

NICKEL

S/AREA:

mm²

TITLE:

P.C. TAIL CONTACT
POLARISING DUMMY

DRAWING NUMBER:

M80-023

SHT
2
OF 2