

Customer Information Sheet

IF IN DOUBT - ASK

©

NOT TO SCALE

THIRD ANGLE PROJECTION

ALL DIMENSIONS IN mm

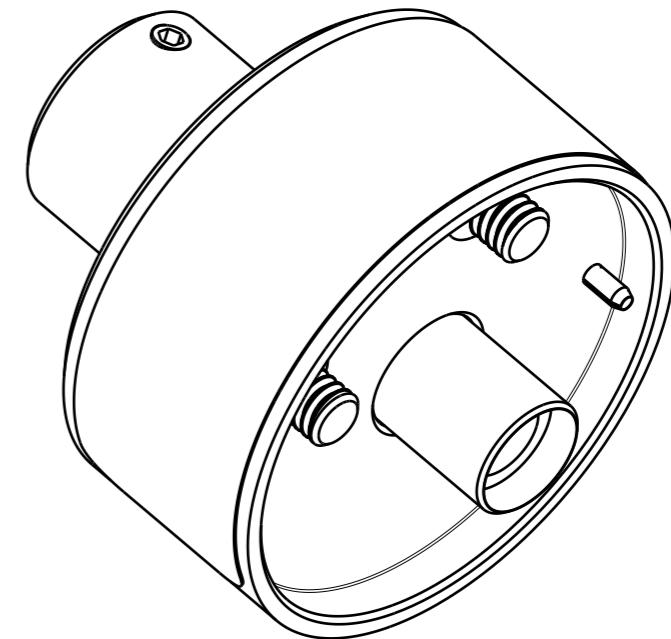
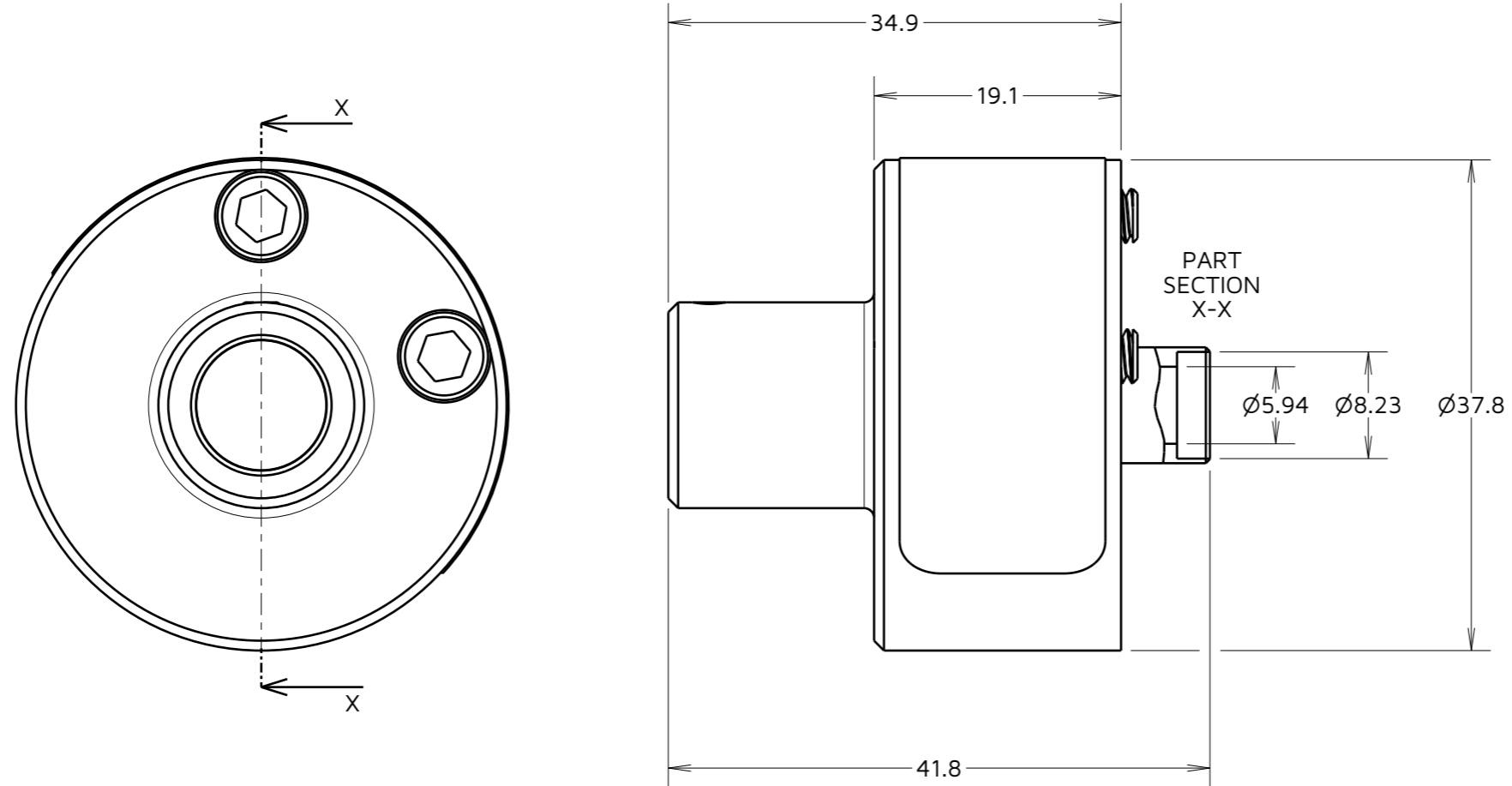

POSITIONER HARWIN PART No.	CRIMP TOOL HARWIN PART No.	CONTACT PART No.	SELECTOR No.	WIRE GAUGE
ZA1-921	ZA1-920	KA1-0450005	SETTING 8	8 AWG

RTP	1	07.09.23	33001
NAME	ISS.	DATE	CN/CO
APPROVED:		M.PLESTED	
CHECKED:		A.BOXALL	
DRAWN:		R.PORTLOCK	
ASSEMBLY DRG:			

NOTES:

- FOR USE WITH ZA1-920 HAND CRIMP TOOL (M300BT - OR EQUIVALENT PNEUMATIC/BATTERY TOOL). SEE IS-XX FOR CRIMPING INSTRUCTIONS.
- TO BE USED WITH KA1-0450005 KONA CRIMP CONTACTS.
- TOOLS ARE PACKED INDIVIDUALLY IN BOXES.

HARWIN

www.harwin.com

TOLERANCES
 X. = ±1mm
 X.X = ±0.50mm
 X.XX = ±0.20mm
 X.XXX = ±0.01mm
 ANGLES = ±5°
 UNLESS STATED

THIS DRAWING AND ANY INFORMATION OR DESCRIPTIVE MATTER SET OUT HEREON ARE CONFIDENTIAL AND COPYRIGHT PROPERTY OF THE HARWIN GROUP AND MUST NOT BE DISCLOSED, LOANED, COPIED OR USED FOR MANUFACTURING, TENDERING OR FOR ANY OTHER PURPOSE WITHOUT THEIR WRITTEN PERMISSION.

MATERIAL:

TITLE:
KA1 KONA CRIMP CONTACT POSITIONER (TP1889)

DRAWING NUMBER:
ZA1-921

SHT
 2 OF 2