

Customer Information Sheet

IF IN DOUBT - ASK

©

NOT TO SCALE

THIRD ANGLE PROJECTION

ALL DIMENSIONS IN mm

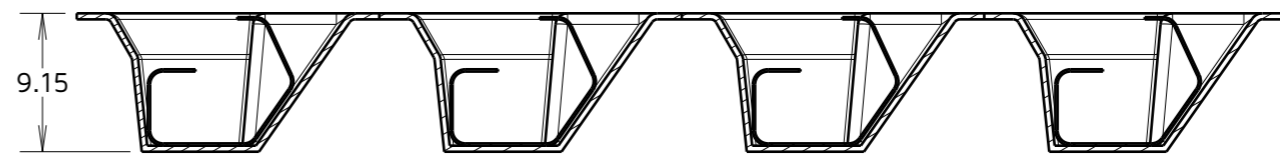
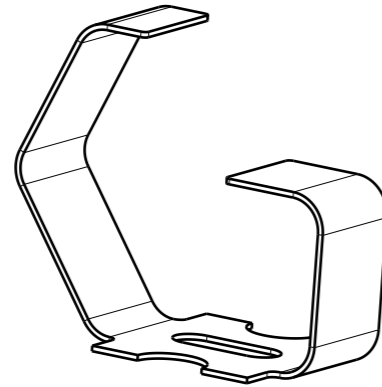
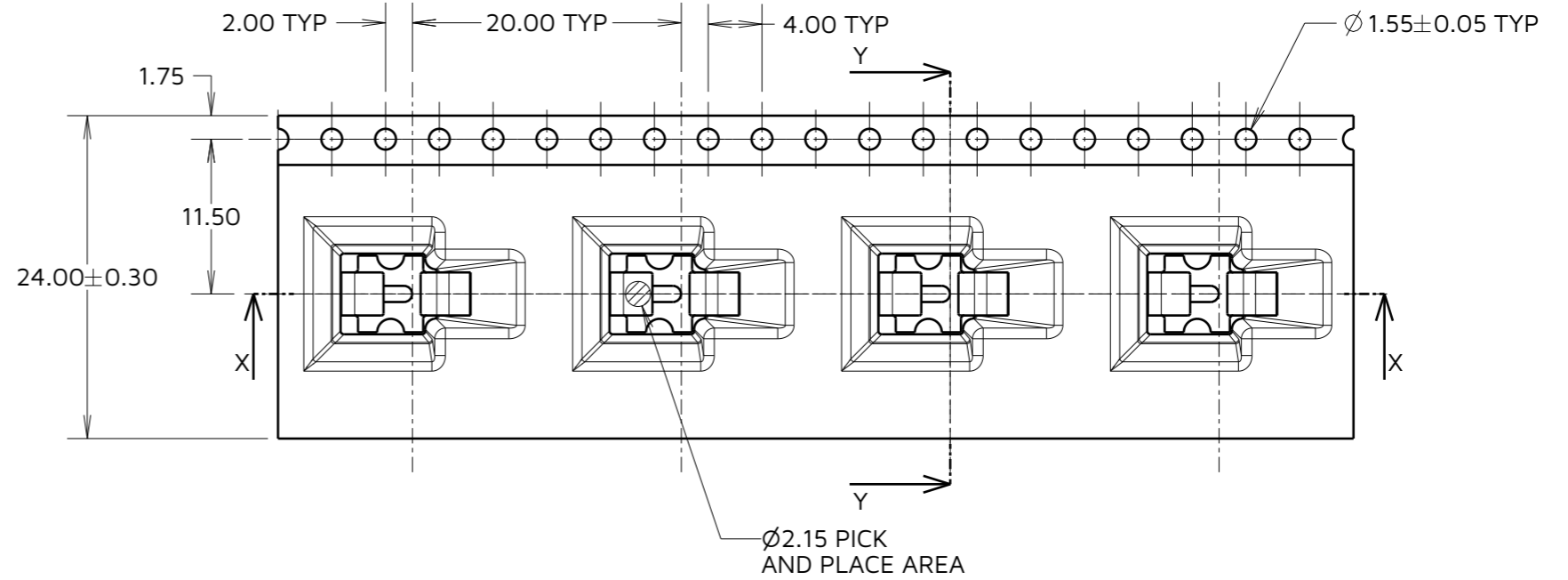
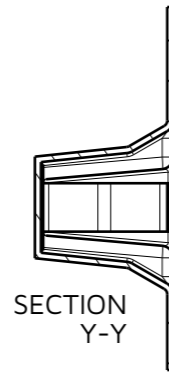
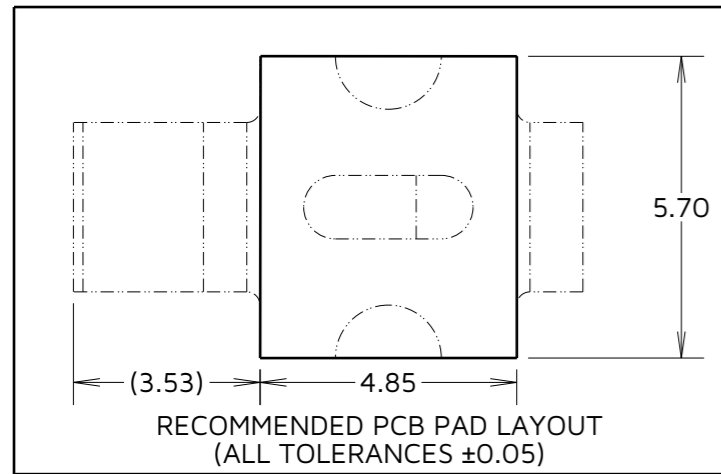

SECTION X-X

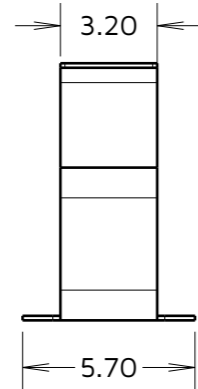
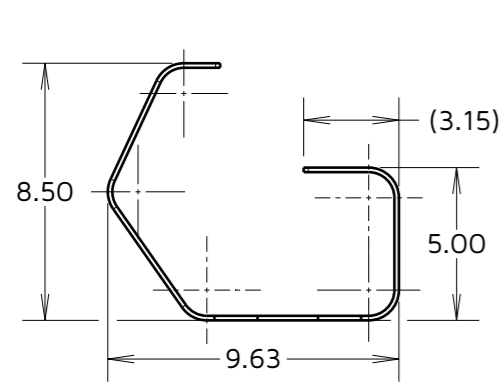

COMPONENT DETAILS

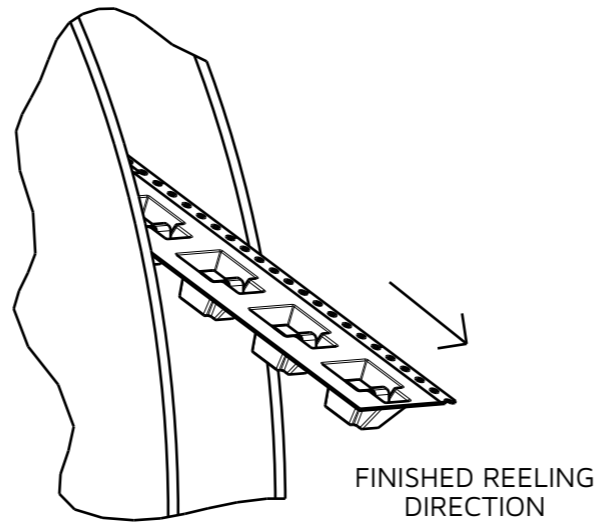

FINISHED REELING DIRECTION

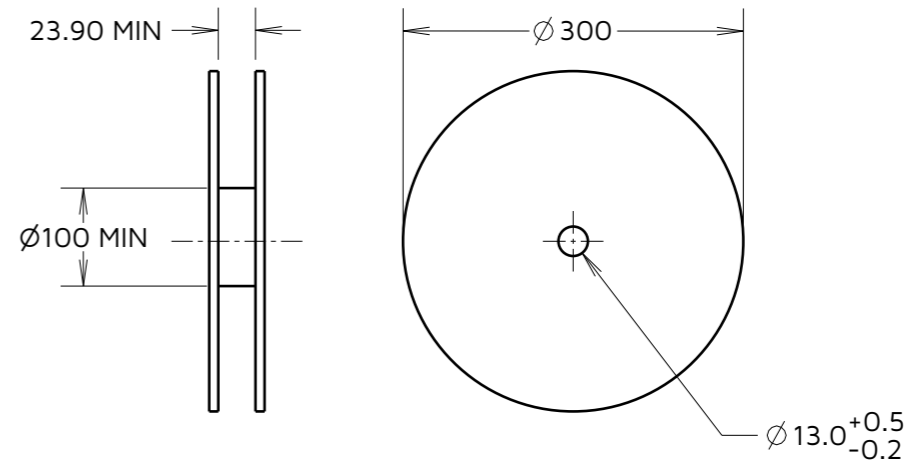

REEL DETAILS

NOTES:

1. QUANTITY OF COMPONENTS PER REEL = 400.
2. THIS PRODUCT IS TAPED AND REELED IN ACCORDANCE WITH EIA-481 (ELECTRONICS INDUSTRIES ASSOCIATION).
3. SEE COMPONENT SPEC C055XX FOR FULL SPECIFICATION (LATEST ISSUE).
4. SEE SHEET 3 FOR RECOMMENDED DEFLECTION DIMENSIONS.

RTP	1	21.07.23	32803
NAME	ISS.	DATE	CN/CO
APPROVED:		M.RUDKIN	
CHECKED:		F.CHRISPINE	
DRAWN:		R.PORTLOCK	
ASSEMBLY DRG:			

HARWIN

www.harwin.com

TOLERANCES
 X. = ±1mm
 X.X = ±0.50mm
 X.XX = ±0.20mm
 X.XXX = ±0.01mm
 ANGLES = ±5°
 UNLESS STATED

THIS DRAWING AND ANY INFORMATION OR DESCRIPTIVE MATTER SET OUT HEREON ARE CONFIDENTIAL AND COPYRIGHT PROPERTY OF THE HARWIN GROUP AND MUST NOT BE DISCLOSED, LOANED, COPIED OR USED FOR MANUFACTURING, TENDERING OR FOR ANY OTHER PURPOSE WITHOUT THEIR WRITTEN PERMISSION.

MATERIAL:

SEE SHEET 3

TITLE:

MULTI-DIRECTIONAL SPRING CONTACT IN TAPE AND REEL

DRAWING NUMBER:

S1981-46R

SHT
2
OF
3

Customer Information Sheet

IF IN DOUBT - ASK



NOT TO SCALE

THIRD ANGLE PROJECTION

ALL DIMENSIONS IN mm

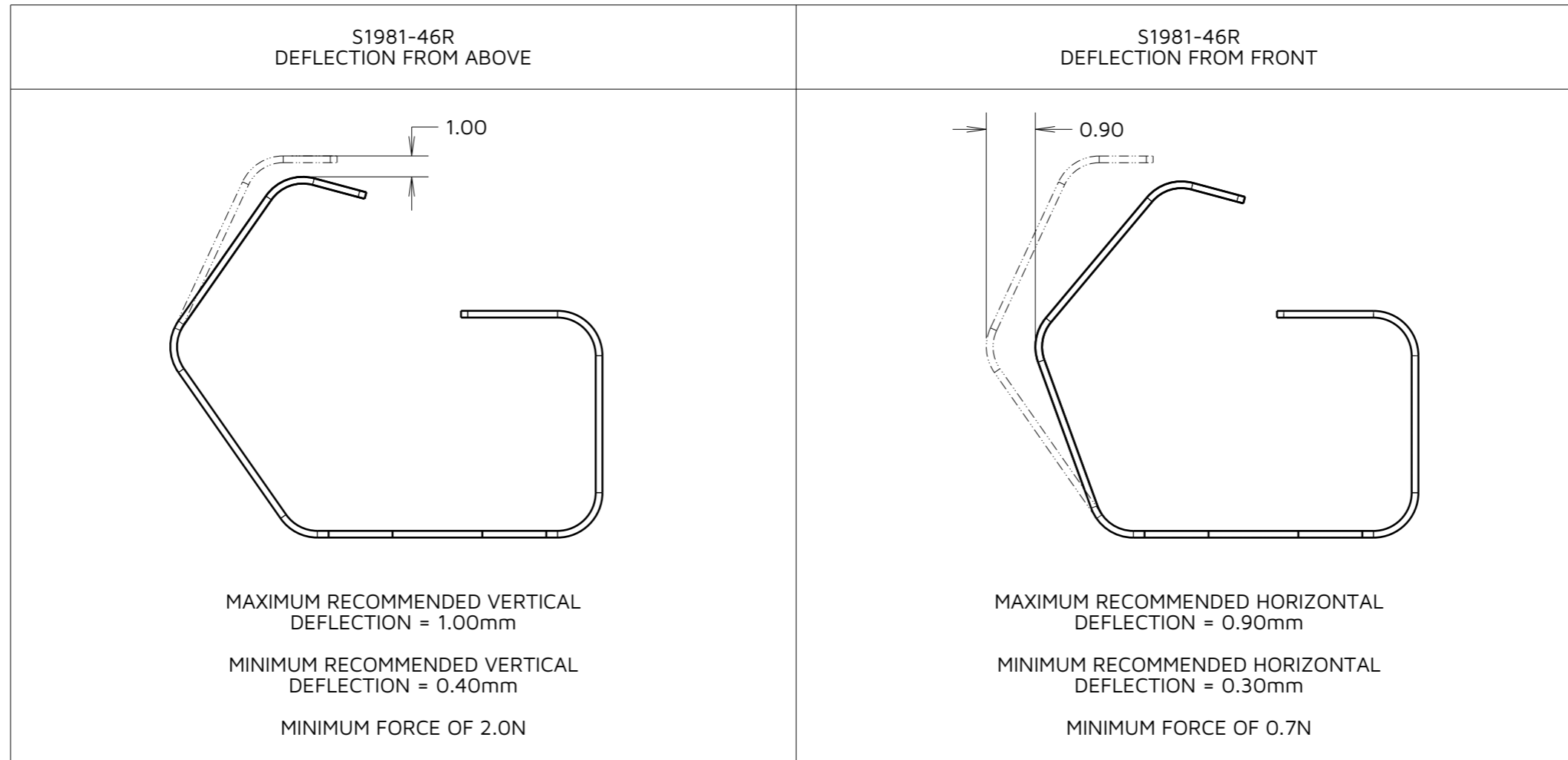

COMPONENT SPECIFICATION:
 MATERIAL = CUPRO NICKEL
 THICKNESS = 0.15mm
 FINISH = 3µm 100% TIN OVER 2µm NICKEL
 (SEE C055XX FOR FULL COMPONENT SPECIFICATION)

RTP	1	21.07.23	32803
NAME	ISS.	DATE	CN/CO
APPROVED:		M.RUDKIN	
CHECKED:		F.CHRISPINE	
DRAWN:		R.PORTLOCK	
ASSEMBLY DRG:			

HARWIN

www.harwin.com

TOLERANCES
 X. = ±1mm
 X.X = ±0.50mm
 X.XX = ±0.20mm
 X.XXX = ±0.01mm
 ANGLES = ±5°
 UNLESS STATED

THIS DRAWING AND ANY INFORMATION OR DESCRIPTIVE MATTER SET OUT HEREON ARE CONFIDENTIAL AND COPYRIGHT PROPERTY OF THE HARWIN GROUP AND MUST NOT BE DISCLOSED, LOANED, COPIED OR USED FOR MANUFACTURING, TENDERING OR FOR ANY OTHER PURPOSE WITHOUT THEIR WRITTEN PERMISSION.

MATERIAL:

SEE ABOVE

TITLE:

MULTI-DIRECTIONAL SPRING CONTACT IN TAPE AND REEL

DRAWING NUMBER:

S1981-46R

SHT
3
OF
3