

HARWIN

CONNECT TECHNOLOGY
WITH CONFIDENCE

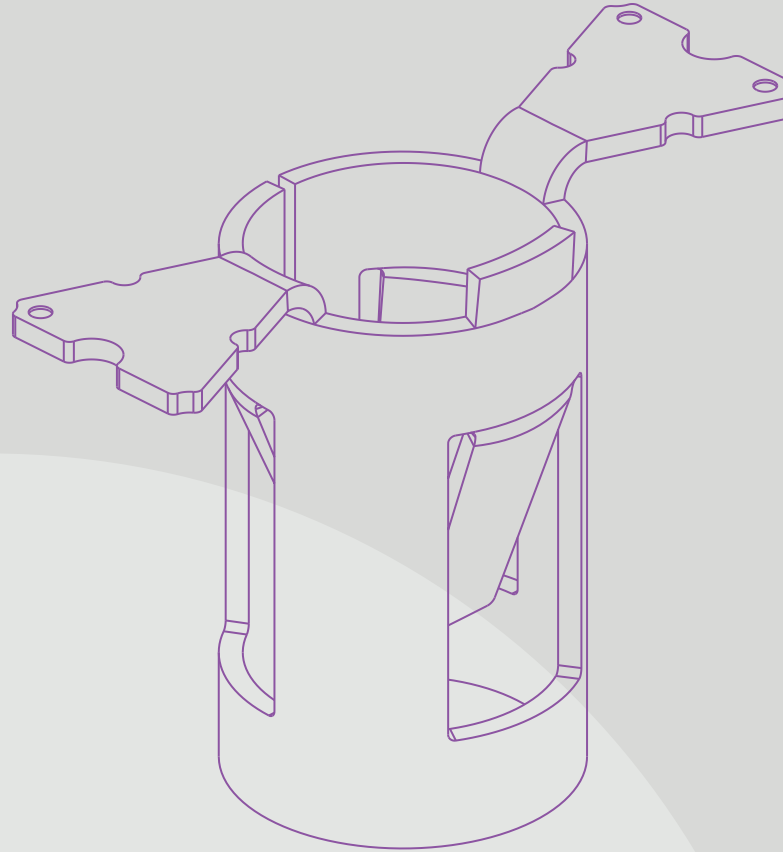

INNOVATIVE
DESIGNS FOR
EASY ASSEMBLY

Ezi
RANGE

SOCKETS

SINGLE FEMALE CONTACT CONNECTION

BOARD MOUNTED SMT AND THROUGHBOARD

HARWIN

SOCKETS

Ezi CONNECTIONS FROM HARWIN.

Throughboard and SMT PCB Contacts

Durable low profile single contact connections; low contact resistance and high conductivity for use with devices or as PCB stacking connections. Use with removable jumper links for hardware programming.

PCB Sockets provide the simplest method to prevent heat damage to sensitive or expensive components, such as sensors and ICs. Simply solder the sockets in a suitable layout on the PCB, then plug the vulnerable item in afterwards.

Ideal for components with oddform termination layouts. Rework, replacement or upgrade does not require any de-soldering and eliminates any further heat damage.

Surface mount sockets are supplied on Tape and Reel with built-in pick and place zones for automated vacuum pick-up.

Mating pin sizes can vary from Ø0.41mm to Ø2.30mm – choose the applicable size from the wide range.

Use the sockets with Harwin's Terminal Pin range for single board-to-board connections, covering a wide range of stacking heights including tolerance flexibility.

FEATURES

- Simple and effective method for connecting PCBs and oddform devices
- Remove de-soldering for rework or replacing / upgrading ICs and modules
- Compact and lightweight for wearables and hand-held devices

APPLICATIONS

- Industrial
- Communications
- Retail
- Instrumentation
- Aerospace and Defense



SOCKETS

SPECIFICATIONS

| MATERIALS | ELECTRICAL | MECHANICAL | ENVIRONMENTAL |
|--|---|--|---|
| Base material: Copper Alloy | Current rating: 5A to 9A (SMT) 2A to 20A (Throughboard) | Durability: 25 to 500 mating cycles min (SMT) 500 min mating cycles (Throughboard) | Operating temperature (SMT): -50°C to +125°C (Sycamore) -40°C to +105°C (Twin Beam) |
| Plating finish: Gold, Tin or Selective Gold + Tin | | Insertion force (SMT): 3.0N min (Sycamore) 2.8N min (Twin beam) | |
| Packaging: Tape and Reel (SMT) Bulk/Loose (Throughboard) | | Contact resistance: 25Ω max | Insertion force (Throughboard): 5.0N min |
| | | Withdrawal force (SMT): 0.3N min | Compliance: RoHS Compliant REACH / CMRT statements |
| | | Withdrawal force (Throughboard): 0.5N min | |

Specifications are subject to change.



SOCKETS

PRODUCT CATEGORIES

Sycamore Contact – SMT

Triple-beam PCB sockets supplied in Tape and Reel for automated assembly. Designed for throughboard location with SMT soldering. Top and bottom entry versions, very-low profile on the PCB. Compatible with either Ø0.8mm to 1.3mm or Ø1.5 to 1.9mm mating pins. Bottom entry also available with extended body option.

Improved vibration resistance and mating cycle durability. Supplied in hard gold finish for wear resistance.

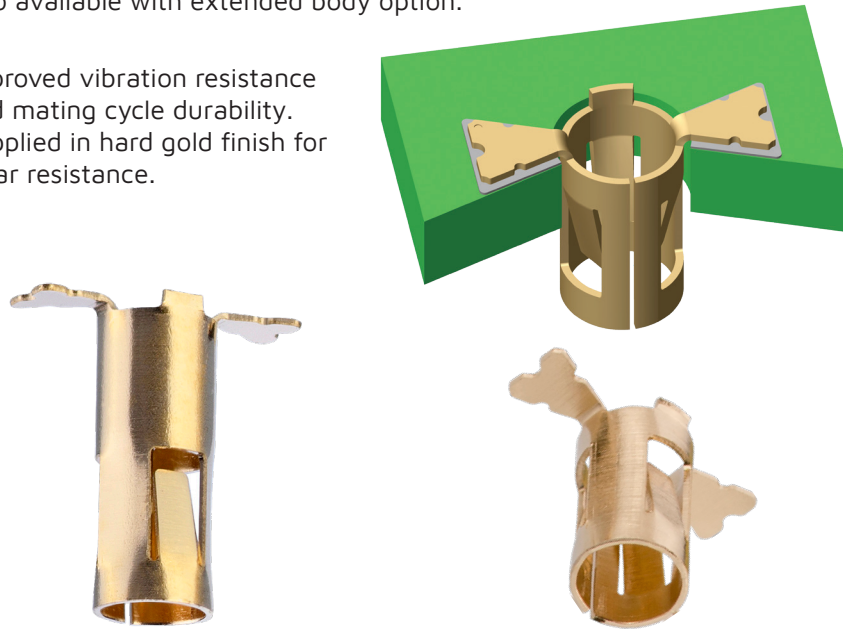

Twin-Beam SMT

Ultra-low profile PCB socket, with just 0.2mm above the board. Cost-effective double beam design, supplied in Tape and Reel for automated assembly. Mounted as throughboard with SMT soldering. Top entry versions compatible with either Ø0.8mm to 1.5mm or Ø1.1 to 1.8mm mating pins. Smaller version can also be located on 2.54mm pitch.



Specifications are subject to change.

SOCKETS

PRODUCT CATEGORIES

Throughboard, Ø0.5mm Mating Pin

Compatible with mating pins in the range Ø0.46-0.51mm. Supplied loose or on metal carrier combs at 2.54mm pitch. Low profile, raised shoulder and extended termination options.



Throughboard, Ø0.8mm Mating Pin

Compatible with mating pins in the range Ø0.60-0.85mm. Supplied loose. Low profile or raised shoulder; knurl option available for added mechanical board retention. Ident groove to differentiate from Ø1mm sockets.



Throughboard, Ø1mm Mating Pin

Compatible with mating pins in the range Ø0.90-1.05mm. Supplied loose. Low profile, raised shoulder or extended termination; knurl option available for added mechanical board retention. Open-ended sockets accommodate longer pin lengths.



Throughboard, Ø2mm Mating Pin

Compatible with mating pins in the range Ø2.00-2.30mm. Supplied loose. Low profile or raised shoulder options.

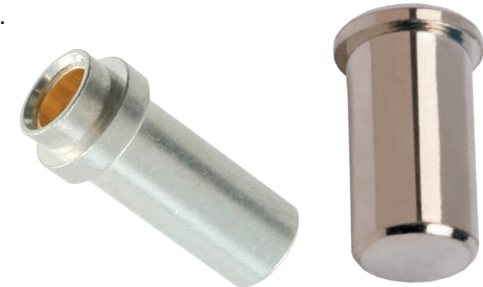

Specifications are subject to change.

SOCKETS

DOWNLOADS

Technical Documents

Ø0.5mm Socket Component Specification [↗](#)

Ø0.8mm Socket Component Specification [↗](#)

Ø1mm Socket Component Specification [↗](#)

Ø2mm Socket Component Specification [↗](#)

Product Training

Product Training Module (PTM) [↗](#)

Test Reports

HT050 – Sycamore Contacts Testing [↗](#)

HT042 – SMT Socket S9091-46R Testing [↗](#)

HT007 – SMT Socket S9101-46R Testing [↗](#)

Specifications are subject to change.



VIEW FULL SERIES & SPECIFICATIONS [HERE](#) [↗](#)

HARWIN

CONNECT TECHNOLOGY
WITH CONFIDENCE



HIGH RELIABILITY
WITH SUPREME
PERFORMANCE



DEPENDABLE
CONNECTIVITY
ACROSS THE BOARD



INNOVATIVE
DESIGNS FOR
EASY ASSEMBLY

HRI
RANGE

BBi
RANGE

EZi
RANGE

FOR FURTHER INFORMATION PLEASE CONTACT:

Europe, Middle East & Africa

E: technical@harwin.com

Americas

E: technical-us@harwin.com

Asia Pacific

E: technical-asia@harwin.com

// WWW.HARWIN.COM